

Modification of a Motorola Sapphire XVIII Mono AM Radio for Volkswagen

to accept 1/4" stereo jack input (from headphone jack of portable device)



Materials:

- Wire - 22 GA solid and 24 GA phone line
- One phone plug to be crimped
- External phone jack box
- 2 resistors - 10K
- 1 POT - 1K
- 1 stereo jack. 1/8"
- SPDT switch
- Heat shrink tubing
- Fimo Clay

Tools:

- Misc wrenches
- Soldering iron
- Screwdrivers

Total cost(iPod not included):

- \$5.00 for working Sapphire XVIII Radio + Schematic
- \$5.00 for electronic parts, most were home from other projects.

I own an Apple iPod (5 gig, first gen), and have been using it in my 1973 STD VW bug with a tape cassette adapter. The quality of this connection is very poor — it varies from day to day, and is not consistent even with one song. I was fed up, and decided enough was enough. Looking over the forums on the web, I decided an FM transmitter would be the best solution — until I remembered I had this radio in the garage.

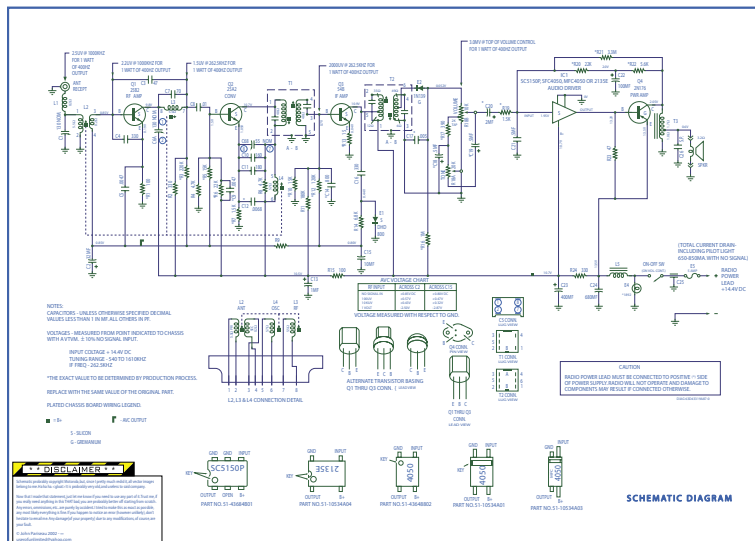

Pulled from a 70's Super Beetle, it appeared to be in working condition. The tuning wheel was missing some teeth, enough to make it worthless. But I remembered there was a schematic with it. It appeared to have two sections to it — radio and the amp. I could not verify this, because I am not knowledgeable in this area.

I posted my question to the VintageVW email list, and received a response - it could be done! After exchanging some emails with Joe Perez, he gave me the solution — where I needed (and how) to patch into the radio.

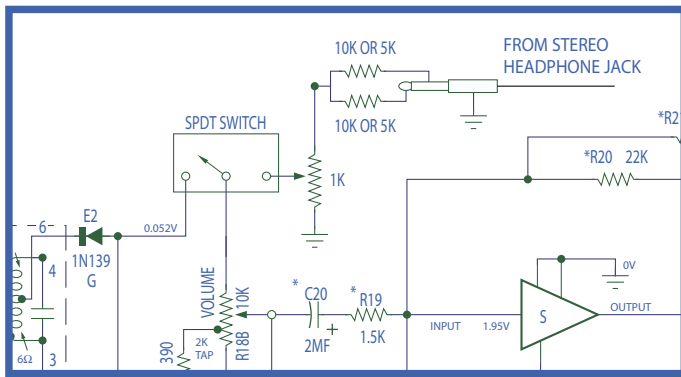

Here is the modified schematic. Very easy. Almost plug and play. It didn't require a lot of inventiveness, I simply located the appropriate spot, and soldered away.

On my particular model, it was just a wire connected to the volume POT. The other end was attached to a circuit board.

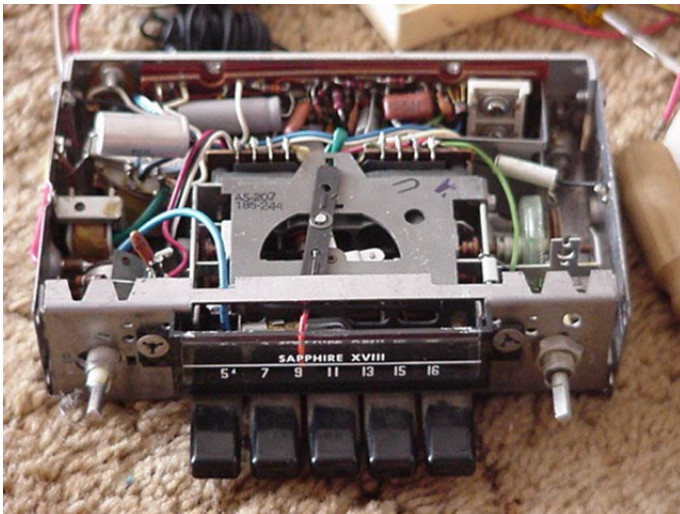

Here is a view of the radio internals. I raised the capacitor to gain access to the POT.

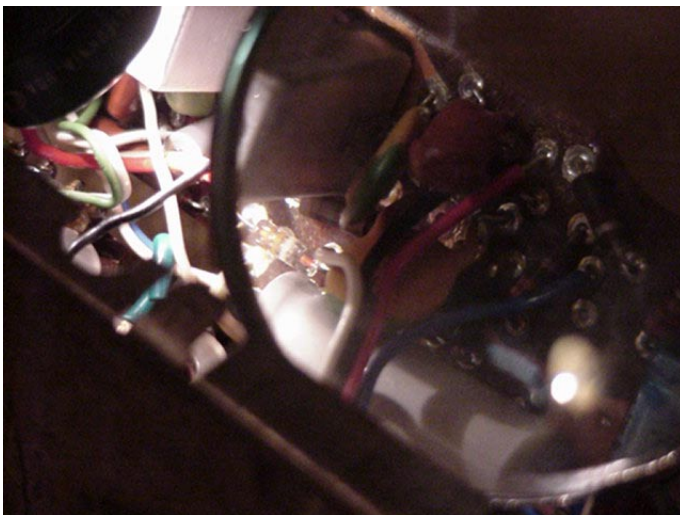

Inside this section is where the B/W wire connects to the PCB. I was afraid I would have to find a specific trace. Which would require splitting the trace with a dremel, and soldering leads to it! Fortunately for me it wasn't.

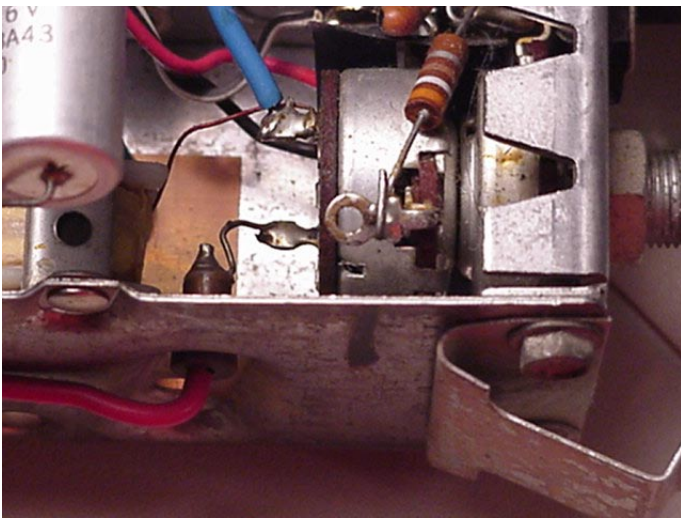

The B/W wire was the only modified part inside the radio - it had to be desoldered. It is near the top, you can see it cross the red and the blue wires.

The SPDT switch when set to position “b” connected these wires together again.

Black wire: Ground

Red Wire: Where B/W wire was soldered to POT

Green Wire: soldered to B/W wire

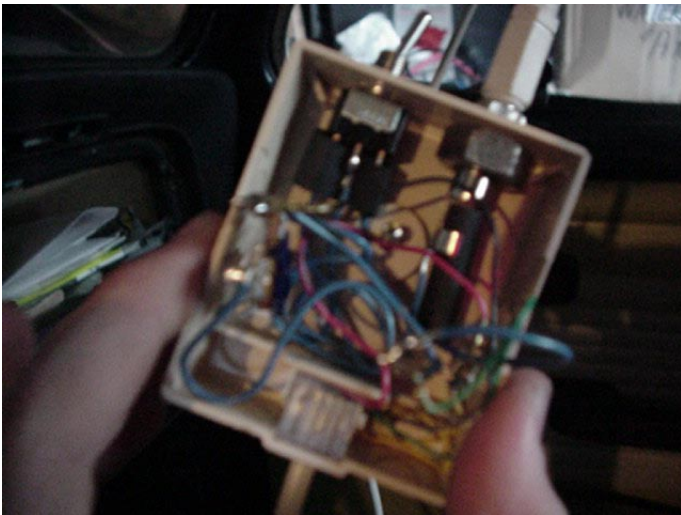

This is the breakout box I made. I crimped a telephone wire with a telephone plug, and used that to connect to this box. You can see all the components here.

Switch: Middle terminal to red wire.
Side terminals to middle of POT and green wire.

1/4” Socket: “Sleeve” to black wire.
*Tip to side terminal of POT

POT: Middle terminal to middle terminal of switch.
Side terminals to tip and black wire.

*Because the radio is mono, the source (iPod) is stereo, I had to join the L and R channels with two 10K resistors. Joe Perez suggested this, or 5K. At the joint, they can go on to the POT. Be sure they don't touch each other on the side where you solder the resistors to the socket leads (L and R).

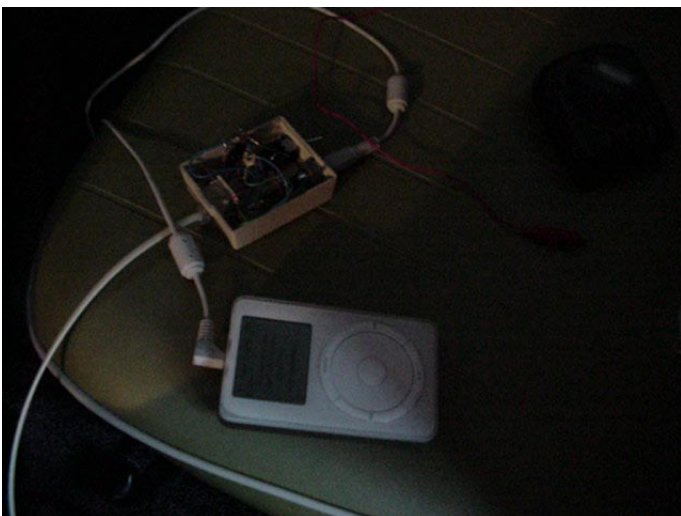

Happy Listening! The quality was surprising. Much better than the tape cassette adapter.

DISCLAIMER:

Any harm, whether physical or psychological is not my fault. Anything you do to your radio is your choice, and any problems are your responsibility. YOU USE THIS PDF AT YOUR OWN RISK. Parental supervision suggested.

Copyright John Pariseau 2002 - ∞
Contact simplifymail@ururk.com for questions regarding reproduction of this document*.

*in any form currently available to mankind for the immediate future (this includes but is not limited to matter transmutation, paper, digital, and reconstructing the pages atom by atom).